

PRODUCT SPECIFICATION

HDR128128

128x128 GRAPHICS
OLED DISPLAY MODULE

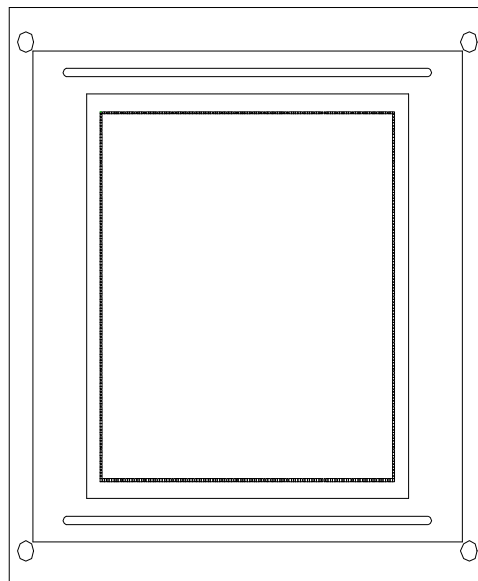

HANTRONIX, INC. 10080 BUBB RD. CUPERTINO, CA 95014	Q.A.: JK	REV.: 0.9	HDR128128	SHEET 1 OF 9
				DATE: 11/13/02

1. MECHANICAL DATA

NO	ITEM	SPECIFICATION	UNIT
1	Dot Matrix	128 (W) x 128 (H)	dot
2	Dot Size	0.32 (W) x 0.32 (H)	mm ²
3	Dot Pitch	0.35 (W) x 0.35 (H)	mm ²
4	Aperture Rate	84	%
5	Active Area	44.77(W) x 44.77(H)	mm ²
6	View Area	49.0(W) x 49.0(H)	mm ²
7	Panel Size	65.2(W) x 59.4(H)	mm ²
8	Panel Thickness	1.85	mm
9	Module Size	72.4(W) x 69.9(H) x 8.5(T)	mm ³
10	Weight		g
11	Duty	1/128	

HANTRONIX, INC.
10080 BUBB RD.
CUPERTINO, CA 95014

Q.A.:

JK

REV.:

0.9

HDR128128

SHEET 2 OF 9

DATE:

11/13/02

2. MAXIMUM RATING OF MODULE

ITEM	MIN	MAX	UNIT	COMMENT
Supply Voltage (V_{dd})	7	12	V	Ta=25°C
Input,Output Pin Voltage	-0.3	$V_{dd}+0.3$	V	Ta=25°C
Operating Temp.	0	50	°C	
Storage Temp	-20	60	°C	
Operating Life Time		6000	hours	Room Temp.
Storage Life Time		10000	hours	Room Temp.

Storage condition : 20~30°C and 0~60%RH

Operation condition : 20~30°C and 0~60%RH @9V

HANTRONIX, INC. 10080 BUBB RD. CUPERTINO, CA 95014	Q.A.: JK	REV.: 0.9	HDR128128	SHEET 3 OF 9
				DATE: 11/13/02

3. ELECTRICAL CHARACTERISTICS OF DRIVER IC

D.C ELECTRICAL CHARACTERISTICS

SYMBOL	PARAMETERS	TEST CONDITION	MIN	TYP.	MAX	UNIT
V ₁₆	Driver Power Supply		7.0		16	V
V _{dd}	Operating Voltage		2.7	5.0	5.5	V
I _{cc}	Operating Current	V _{dd} =5V XSCL=1MHZ No output load			1	mA
I _{sb}	Standby Current	DSPOF/= 0V			1	uA
V _{ih}	Input Hi. Voltage		2.4		5.0	V
V _{il}	Input Low Voltage		0.0		0.8	V
I _{segoh}	Segment on Output Current	V _{segoh} = 7V	-0.30		-300	uA
I _{rowol}	Row on output Current	V _{rowol} = 0.4V			100	mA
I _{li}	Input Leakage Current	V _{DD} =5V			2	uA

A.C ELECTRICAL CHARACTERISTICS

SYMBOL	PARAMETERS	MIN.	TYP.	MAX.	UNIT
T _{SD}	Data latch in setup time	50			ns
T _{DH}	Data latch in hold time	50			ns
T _{WCP}	XSCL pulse cycle time	140			ns
T _{CL}	XSCL low to LP high	20			ns
T _{WLD}	LP high width	140			ns
T _{CDH}	Common scan pulse latch hold time	50			ns
T _{LSEG}	LP low to segment outputs	200			ns
T _{LCOM}	LP low to common outputs	10			ns

HANTRONIX, INC. 10080 BUBB RD. CUPERTINO, CA 95014	Q.A.:	REV.:	HDR128128	SHEET 4 OF 9
	JK	0.9		DATE:

4. ELECTRO-OPTICAL CHARATERISTICS OF MODULE

GENERAL ELECTRICAL SPECIFICATION

Average Luminance	45cd/m ²
Forward Voltage	9V
Duty	1/128
Frame Rate	120 Hz

PULSED ELECTRICAL AND OPTICAL SPECIFICATIONS

PARAMETER	MIN	TYP.	MAX	UNITS	COMMENTS
Forward Voltage		9		V	Initial
Ivp		(20)	(30)	mA	all pixels on
Ivcc		(26)	(30)	mA	all pixels on Whole module
Emissive Power Consumption		(180)	(270)	mW	All pixels on
Pixel Luminance	(40)	(45)		cd/m ²	Display Average
Peak Emission Frequency		524		nm	Green
Emission Frequency Range		503-553		nm	1/2 max intensity
Pixel Color coordinates	0.23 0.62	0.28 0.67	0.30 0.71		x,y(CIE 1931)
Dark Room Contrast		>1:100			
Viewing Angle Uniformity	>160			degree	

Note:Optical Measurment taken at 1/128 duty, 120 Hz Frame rate with PT0253 & PT0250 Driver IC and BVR=1K,DVR=? .

HANTRONIX, INC. 10080 BUBB RD. CUPERTINO, CA 95014	Q.A.:	REV.:	HDR128128	SHEET 5 OF 9
	JK	0.9		DATE: 11/13/02

5. FUNCTION BLOCK DIAGRAM

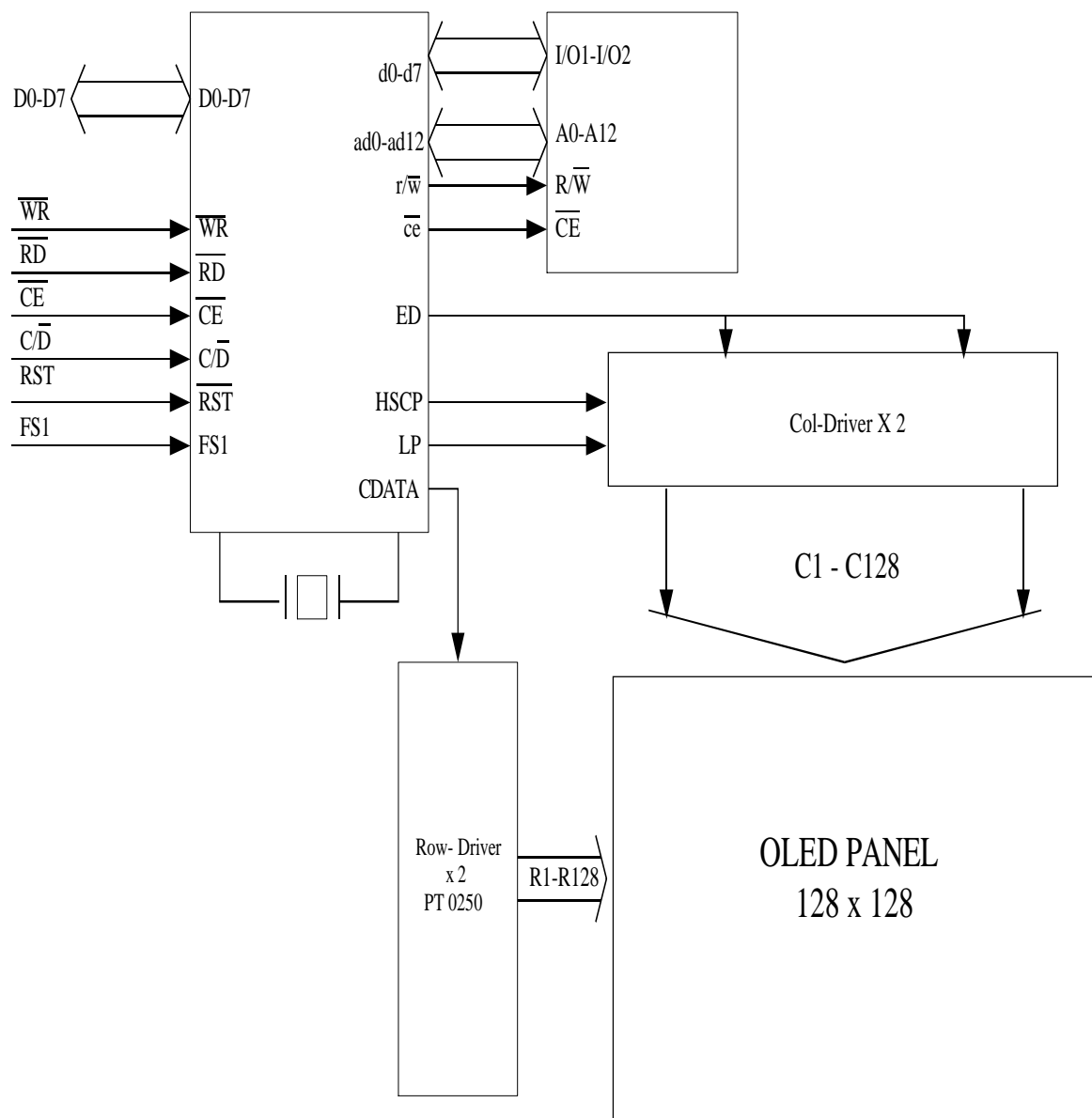

HANTRONIX, INC. 10080 BUBB RD. CUPERTINO, CA 95014	Q.A.: JK	REV.: 0.9	HDR128128	SHEET 6 OF 9

6. PIN ASSIGNMENTS

PIN DESCRIPTION

Pin Name	Pin No.	Type	Description
GND	1	I	Power Supply (0V)
VDD	2	I	Power Supply (5V)
VEE	3	I	Power Supply (for panel :9V)
$\overline{\text{WR}}$	4	I	Data Write
$\overline{\text{RD}}$	5	I	Data Read.
$\overline{\text{CE}}$	6	I	Chip Enable for T6963C.
$\overline{\text{C/D}}$	7		WR =L C/D= H: Command Write C/D=: L Data Write RD =L C/D= H: Status Read C/D= L: Data Read
$\overline{\text{RST}}$	8	I	H: Normal mode. L: Initialize T6963C
DB0	9	I/O	Data I/O pin between CPU and T6963C.
DB1	10	I/O	Data I/O pin between CPU and T6963C.
DB2	11	I/O	Data I/O pin between CPU and T6963C.
DB3	12	I/O	Data I/O pin between CPU and T6963C.
DB4	13	I/O	Data I/O pin between CPU and T6963C.
DB5	14	I/O	Data I/O pin between CPU and T6963C.
DB6	15	I/O	Data I/O pin between CPU and T6963C.
DB7	16	I/O	Data I/O pin between CPU and T6963C.
FS	17	I	Pin for selection of font FS=H: 8x8 FS=L: 6x8
NC	18		
NC	19		
DISB	20	I	Sleep mode controller(ACTIVE:LOW)

7. RELIABILITY TEST

ITEM	TEST CONDITION
High Temp operation	50°C 100hours
Low Temp operation	0°C 100hours
High Temp storage	60°C 200hours
Low Temp storage	-20°C 200hours
High Temp & High Humi. Storage	65°C 95%RH 144hours
Temperature cycle	-20°C : 30min ? 25°C : 5min ? 60°C : 30min ? 25°C : 5min 5 cycle

HANTRONIX, INC.
10080 BUBB RD.
CUPERTINO, CA 95014

Q.A.:

JK

REV.:

0.9

HDR128128

SHEET 8 OF 9

DATE:

11/13/02

8. EXTERNAL DIMENSION

Specification:
 Display: OLED
 Dot Matrix: 128x128
 Dot Size: 0.32x0.32
 Dot Pitch: 0.35x0.35
 Aperture Rate: 0.84
 Active Area: 44.77x44.77
 View Area: 49x49
 Duty: 1/128

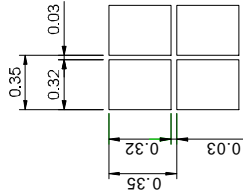

Pin No.	Pin Name	Pin No.	Pin Name
1	GND	11	DB2
2	VDD	12	DB3
3	VEE	13	DB4
4	WR	14	DB5
5	RD	15	DB6
6	CE	16	DB7
7	C/D	17	FS
8	RST	18	NC
9	DB0	19	NC
10	DB1	20	DISB

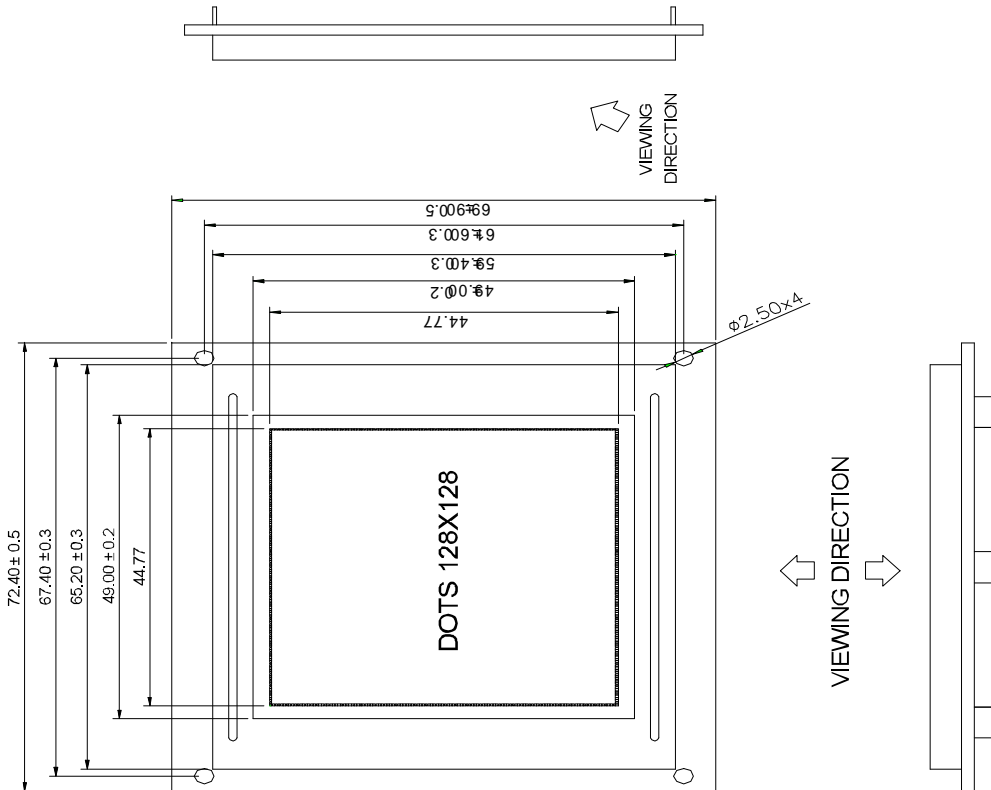

HANTRONIX, INC. 10080 BUBB RD. CUPERTINO, CA 95014	Q.A.: JK	REV.: 0.9	HDR128128	SHEET 9 OF 9
				DATE: 11/13/02